

MEDI-ALARM

U S E R M A N U A L

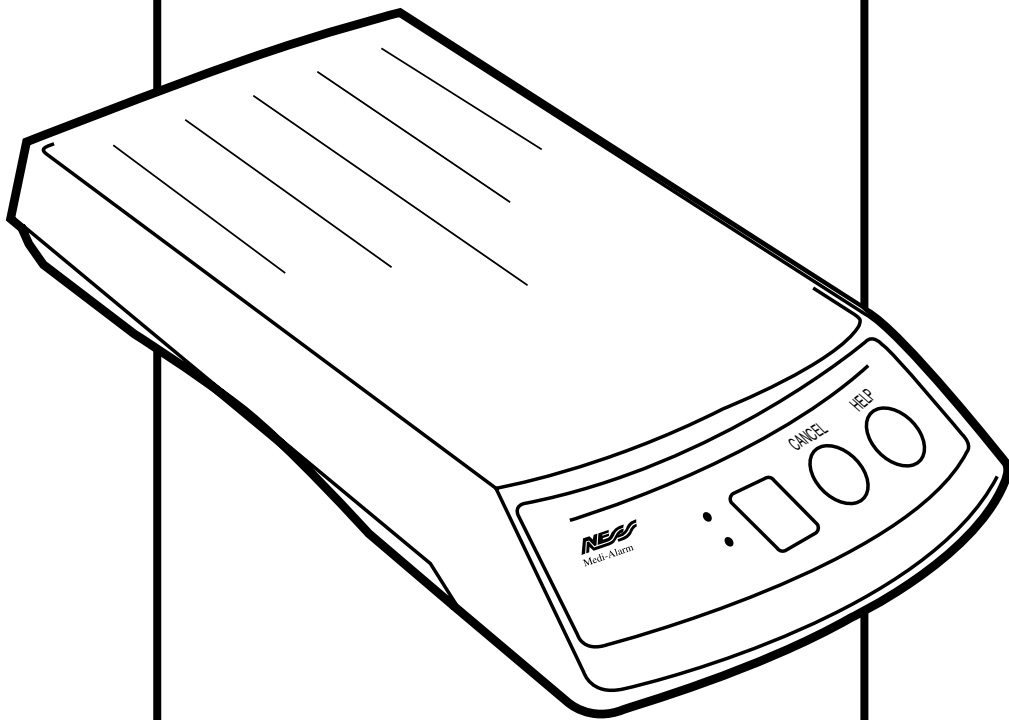

Security Products



Security Products

www.ness.com.au

*“Australia’s
largest designer
and manufacturer
of high quality
security products”*



Head Office:
Ness Security Products Pty Ltd
ABN 28 069 984 372
4 / 167 Prospect Hwy
Seven Hills NSW 2147 Australia
Ph +61 2 8825 9222
Admin Fax +61 2 9838 8508
ness@ness.com.au

SYDNEY
4 / 167 Prospect Highway
Seven Hills NSW 2147
Ph 02 8825 9222 Fax 02 9674 2520
sales@ness.com.au

MELBOURNE
24 Terracotta Drive
Blackburn VIC 3130
Ph 03 9875 6400 Fax 03 9875 6422
nessmelb@ness.com.au

BRISBANE
Unit 3, 471 Lytton Road
Morningside QLD 4170
Ph 07 3399 4910 Fax 07 3217 9711
nessbris@ness.com.au

PERTH
Unit 1, 567 Newcastle Street
West Perth WA 6005
Ph 08 9328 2511 Fax 08 9227 7073
nessper@ness.com.au

ADELAIDE
13 Weaver Street
Edwardstown SA 5039
Ph 08 8277 7255 Fax 08 8276 3028
adelaide@ness.com.au

NESS LIMITED WARRANTY:

Ness Security Products Pty Ltd warrants its products to be free from manufacturing defects in materials or workmanship for the warranty period as detailed in Ness' Terms and Conditions of Sale and all other obligations detailed in those Terms and Conditions.

Whilst Ness Security Products, the manufacturer, is accredited to ISO9001 and all possible care and diligence has been applied during manufacture to ensure the reliable operation of this unit, there are various external factors that MAY impede or restrict the operation of this unit in accordance with the product's specification.

These factors include, but are not limited to,

1. Failure to communicate to the monitoring company due to a telephone service provider's line fault or due to the incorrect configuration of the telephone/Product to the Telephone Network. It is the responsibility of a qualified Installer to ensure correct configuration to the telephone network.
2. Erratic or reduced radio range as detailed in the manufacturer's specifications. Ness' radio based products are sophisticated low power devices however the presence of in-band radio signals, high power transmissions or interference caused by electrical appliances e.g. computers, televisions etc. MAY reduce the range performance. Whilst such occurrences are unusual, they are possible none the less. If a problem such as this is encountered and the performance is unsatisfactory, the installer of the product should be contacted immediately.
3. Unauthorised tampering, physical damage, electrical interruptions such as mains failure, electrical spikes or lightning.

Ness Security Products is not an insurer of either property or safety of the user and limits its liability for any loss or damage including incidental or consequential damages to Ness' original selling price. There are no warranties, expressed or implied, which extend beyond the description on the face hereof. Ness Security Products recommend that the system is tested weekly to confirm reliable operation.

CONTENTS

4

MEDI-ALARM FEATURES

5

USING MEDI-ALARM

6

SPECIAL FUNCTIONS

7

DISPLAYS AND WARNINGS

8

MAINTENANCE & SPECIFICATIONS

INTRODUCTION

Your Medi-Alarm has been designed to provide you with the freedom and peace of mind in the knowledge that should you need assistance or help it is available to you 24 hours a day with the simple press of a button.

The modern slim line design of the Medi-Alarm allows it to be placed unobtrusively under your telephone, a flashing green light on the front panel assures you that everything is O.K. and the Medi-Alarm is ready when you need help. Help can be summoned by pressing either the red Help button on the Medi-Alarm or by pressing a button on your personal radio pendant which you can carry with you both inside or in the garden and can be placed within easy reach whilst in bed.

The Medi-Alarm has been built to the highest of technical standards by a company with over 30 years experience in the business of designing and manufacturing products for the protection of people and property and accredited to the international ISO9001 Quality Standard.

Your Medi-Alarm can be supplied with additional fixed or portable pendants which can be placed around the home as needed. Please contact your supplier for more information.

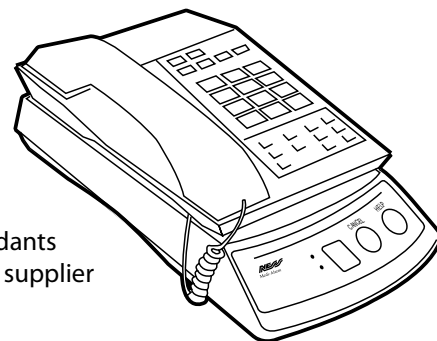

MEDI-ALARM FEATURES

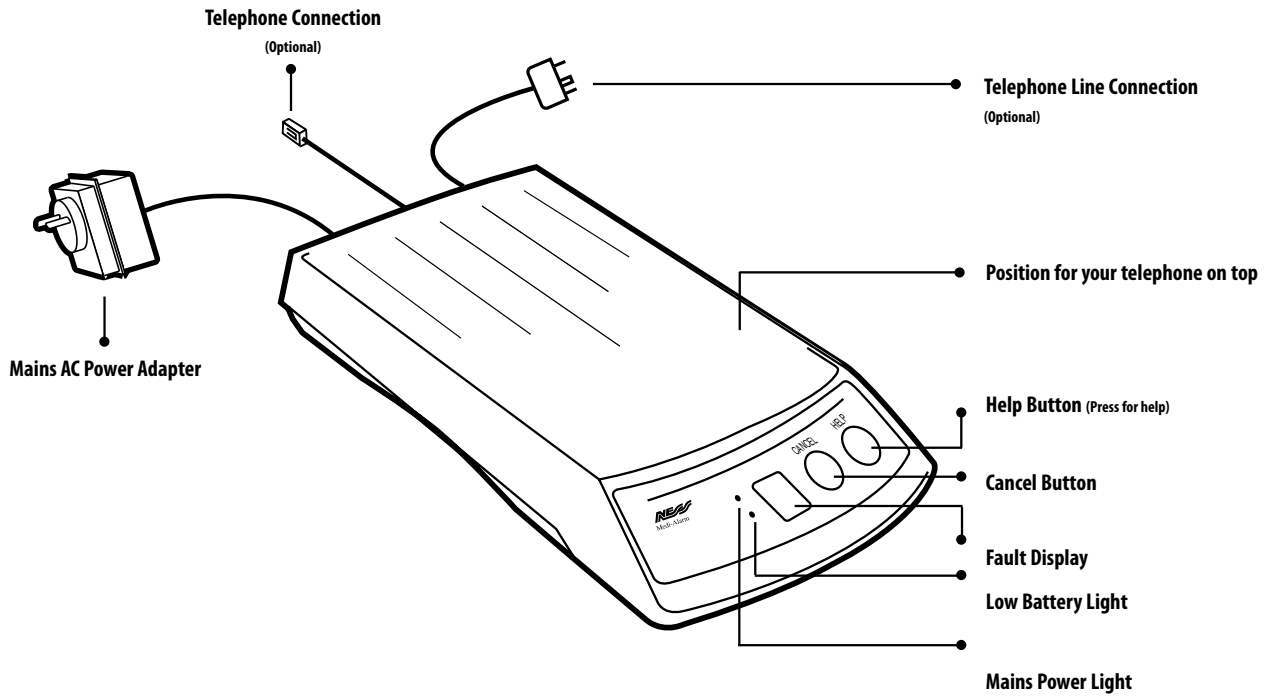

UNDERNEATH

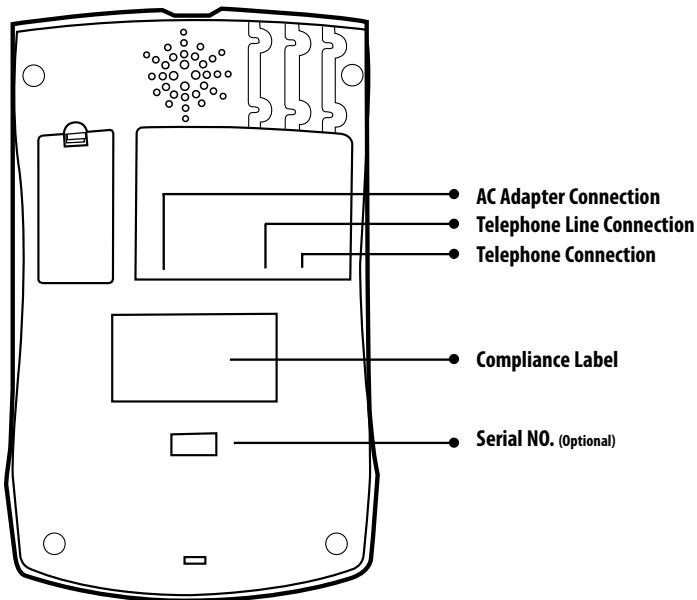

PENDANT TRANSMITTER

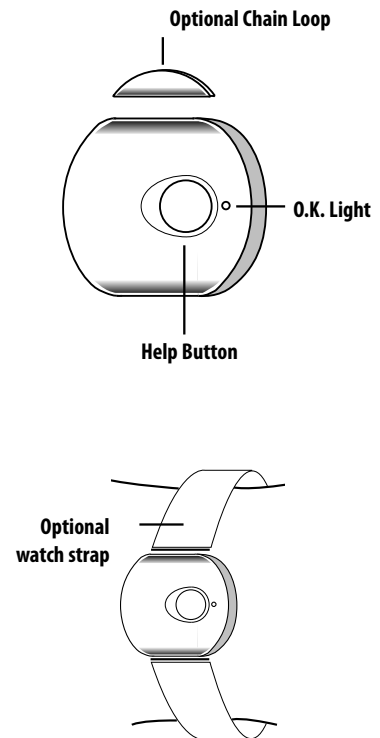

USING MEDI-ALARM

NORMAL

Your Medi-Alarm will normally look like this;

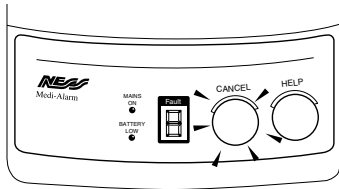

The MAINS ON light should be On and the green Cancel light will blink every 4 seconds.

(See page 7 for other conditions)

TO CALL FOR HELP

You can make your Medi-Alarm call for help by either;

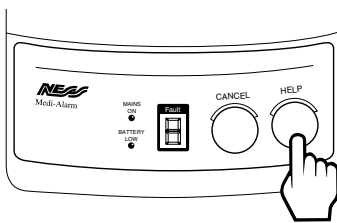

Press the red HELP button on the Medi-Alarm.

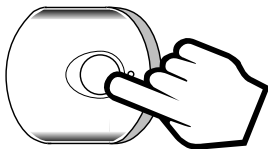

or Press the button on your pendant for 2 seconds.

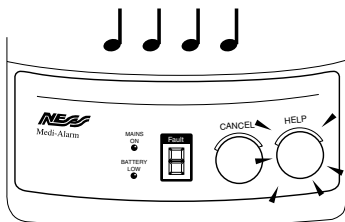

The red HELP button will flash rapidly and the Medi-Alarm will beep for 15 seconds.

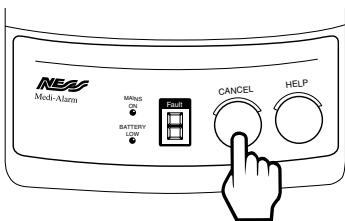

This is a pre-alarm Help warning, while this warning is sounding you can cancel the Help alarm by pressing the green CANCEL button.

If the CANCEL button is not pressed within the 15 second pre-alarm time then your Medi-Alarm will dial your Central Monitoring station using the telephone line. (Note -Your Medi-Alarm will cut off your telephone for the duration of the call to ensure that there is no interference to the call, this will normally take about 15 seconds). The red HELP button will now flash every 4 seconds to indicate that your Medi-Alarm is calling for help.

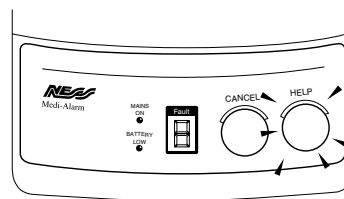

When your Central Monitoring station has received the Help call your Medi-Alarm will beep 7 times to let you know that the call has been received.

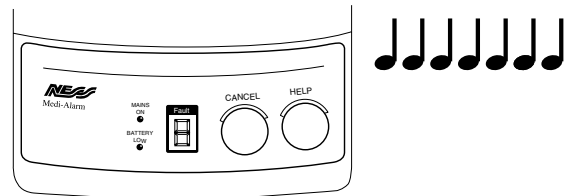

(OPTIONAL)

Your Central Monitoring Station may call you to see if you need assistance. If you are O.K. and the Red HELP button is still flashing then the Central Monitoring

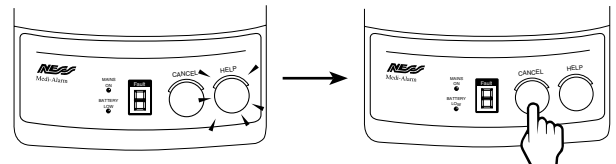

Station may instruct you to press the green CANCEL button to clear the Help message and turn the red HELP light off. This will also make the Medi-Alarm dial the Central Monitoring station and send a message to say that you are O.K. this will again make the Medi-Alarm cut off your telephone for the duration of the call (about 15 seconds).

SPECIAL FUNCTIONS

Your Medi-Alarm may have been programmed with one or more special features by your installer, these are described below, check with your Monitoring company if you have any queries about these or other features.

PILL TIMER

CANCEL BUTTON FLASHES AND BEEPS FOR 10 MINUTES.

Your Medi-Alarm can be programmed to produce regular warning beeps for use as a medication reminder.

The Pill Timer can be programmed to work in 1 hour increments up to 255 hours, this makes it possible to have daily warnings or weekly warnings if needed.

When the Pill Timer is active it will be pre-set by your installer to provide warning beeps and flash the HELP light for 10 minutes as a reminder to take your medication. You can stop the warning by pressing the CANCEL button while the warning is happening.

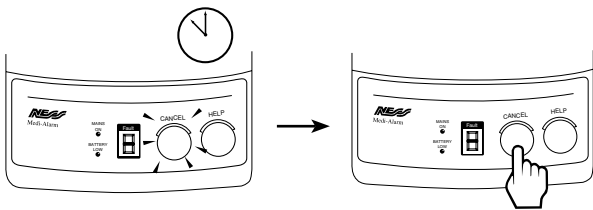

Note - The Pill Timer does not send a help message to your Central Monitoring station, the warning is a reminder for you only.

HOW IT WORKS (For example)

1. You may have to take regular medication every 2 days, if so your installer will program your Medi-Alarm accordingly.
2. You may decide that the most convenient time for the warning to occur is at 10 o'clock in the morning. To start the Pill Timer all you have to do is press the green CANCEL button at 10 o'clock on the first morning.
3. 2 days after the Pill Timer has been started, your Medi-Alarm will start beeping and flashing the green CANCEL button, 10 minutes before the set time (10 o'clock) as a reminder to take your medication.

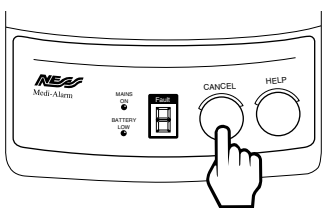

4. Press the green CANCEL button to stop the warning this also re-starts the Pill Timer for your next warning.

If you do not press the green CANCEL button while the warning is sounding (10 minutes) the Pill timer will de-activate and it will not re-start until the CANCEL button is pressed again.

You can use this as a useful feature if you wish to change the timer to commence at say 4 o'clock in the afternoon. Simply press the CANCEL button at 4 o'clock in the afternoon, to now have the Pill timer warning to be given every 2 days at 4 o'clock in the afternoon.

If you wish to change the timer to a different interval e.g. every week, then your Central Monitoring station may be able to change this time over the phone or your installer can change it for you.

INACTIVITY MONITOR

A SERIES OF FIVE BEEPS WHILE THE RED HELP LIGHT IS FLASHING.

Your Medi-Alarm may have been programmed by your installer to ensure that you have not had an accident and are unable to move and you do not have a Pendant with you to call for Help.

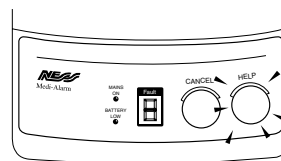

After a fixed period of time without any activity, the Inactivity Monitor will automatically send a HELP message to your Central Monitoring station. The red HELP light will flash and the beeper will sound warning beeps.

You can Cancel the Help message by pressing the green CANCEL button during the 15 second warning time.

TEST CALLS

Your Medi-Alarm may have been programmed by your installer to send regular Test Calls to the Central Monitoring Station.

The purpose of Test Calls is to verify the correct operation of the Medi-Alarm and your telephone line.

Note that while a Test Call is taking place the Medi-Alarm will temporarily disconnect your telephone for a few seconds, although Test Calls are normally programmed to take place overnight when there is less likelihood of the telephone being in use.

DISPLAYS AND WARNINGS

MAINS LIGHT FLASHING

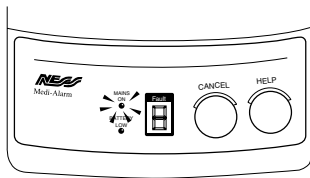

A.C. power failure - Check and make sure that the Mains Power Pack is plugged in and turned on at the power point.

BATTERY LIGHT FLASHING

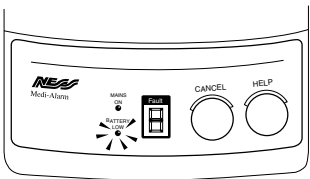

Medi-Alarm Battery is Low and needs replacing (see page 8).

FAULT DISPLAYS

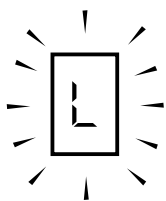
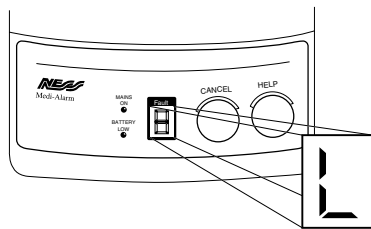

The telephone line has failed. Check and make sure that the telephone lead is plugged in. (Medi-Alarm will beep constantly, beeps can be stopped by pressing the green CANCEL button.)

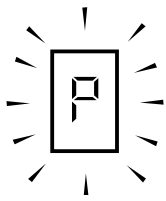

Your Pendant Battery is low and needs servicing (see page 8).

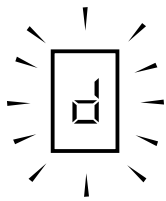

The Medi-Alarm dialler failed to send a message to your Central Monitoring station. Check and make sure that the telephone lead is plugged in, contact your Central Monitoring station.

HELP LIGHT FLASHING QUICKLY

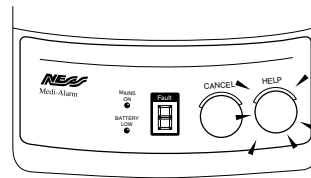

The Medi-Alarm is about to send a Help message to your Central Monitoring station.

HELP LIGHT FLASHING SLOWLY

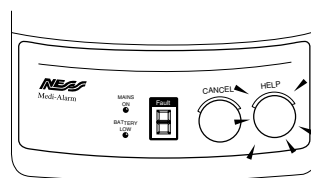

The Medi-Alarm is sending a Help message to your Central Monitoring Station and is waiting to send an I'm O.K. message.

The Cancel button will need to be pressed to send the I'm O.K. message.

CANCEL LIGHT IS FLASHING QUICKLY (WITH BEEPS)

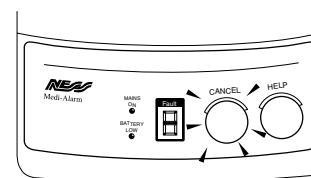

The Pill Timer is active, Press the CANCEL button to clear.

PENDANT LIGHT FLASHING

or not lighting at all when the button is pressed.

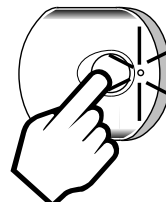

The Pendant battery is low or flat. Contact your installer for service.

BATTERY MAINTENANCE

Your Medi-Alarm will warn you if the battery in the main unit or the Pendant battery is running low. It will also warn your Central Monitoring station. Contact your installer for service.

If your Pendant battery is Low then the Medi-Alarm will warn you by flashing a "P" on the Fault display. The "P" display will stay until the Pendant has been serviced by your installer.

When a button is pressed on your pendant, the red light will flash if the battery is low.

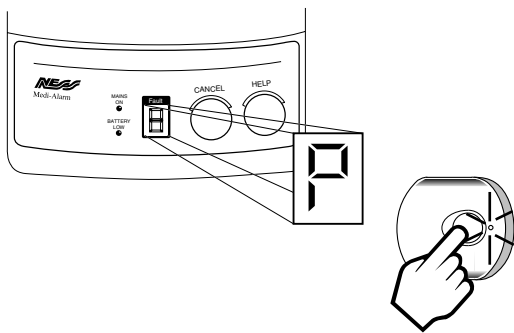

The hatch on the underside of the main unit conceals the battery enable switch. This switch should always be in the on position in normal operation.

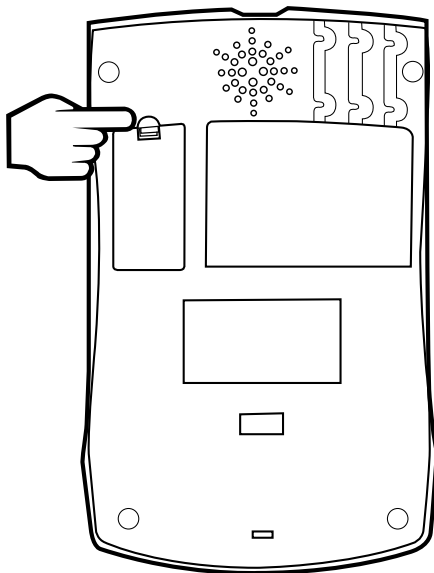

SPECIFICATIONS

MEDI-ALARM MAIN UNIT

FRONT PANEL FUNCTIONS	HELP button, CANCEL button
FRONT PANEL INDICATORS	7 segment LED display, Mains On LED, Batt Low LED
AUDIBLE INDICATOR	Built-in beeper with various functions
MONITORING	Built-in digital dialler for optional connection to a central monitoring station
ALARMS REPORTED	Help from main unit, Help from pendant/s, Inactivity alarm, AC Fail, Low battery main unit, Low battery pendant/s, Test calls
POWER SUPPLY	17V AC 300mA Plug Pack (supplied)
BACKUP BATTERY	8.4 Volt Ni-MH 270mAh (supplied)
DIMENSIONS (h x w x d)	35 x 170 x 275 mm

MEDI-ALARM PENDANT

BATTERY (Supplied)	3V Lithium (sealed)
BATTERY SHELF LIFE (approx.)	5 years
SUPPLIED WITH	Wristwatch strap and neckchain
DIMENSIONS (h x w x d)	46 x 46 x 12 mm

APPROVALS

EMC COMPLIANCE

AS/NZ CISPR 22

TELECOM

Australia - ACIF S002-2001

New Zealand - PTC200

SAFETY

AS/NZS 60950:2000



Document Part Number 890-118

COPYRIGHT NOTICE

All rights reserved. No part of this publication may be reproduced, transmitted or stored in a retrieval system in any form or by any means, electronic, mechanical, photocopying, recording, or otherwise, without the prior written permission of Ness.

Ness reserves the right to make changes to features and specifications at any time without prior notification in the interest of ongoing product development and improvement.

© 2005 Ness Security Products Pty Ltd ABN 28 069 984 372